



Profit from the Eagle Advantage®

# Specification Sheet

## Short Form Specifications

Eagle Stainless Steel Utility Cart, model \_\_\_\_\_.  
Three stainless steel shelves welded to angle legs. Galvanized  
caster channel frame. Available with standard 1"-high upturn  
on ends and rear of top and center shelves, or 1"-high upturn  
on all sides of all shelves. Four 4"-diameter swivel plate  
casters (two with brakes). 1"-diameter handle on one end.



*"UC" cart with upturns on ends and rear of top and center shelves*

Item No.: \_\_\_\_\_  
Project No.: \_\_\_\_\_  
S.I.S. No.: \_\_\_\_\_

## Stainless Steel Utility Carts

### MODELS:

- UC-311       UUC-311
- UC-322       UUC-322

### Features on all carts...

- Three 20-gauge stainless steel shelves.
- Type 300 stainless steel shelves.
- 16-gauge stainless steel angle legs.
- Galvanized bottom frame consists of front-to-back caster channels and left-to-right support angles.
- 1" (25mm)-high upturns.
- Each shelf is hemmed for further strength and stability.
- 12½" (318mm) shelf clearance.
- Legs provided with bumpers.
- 4" (76mm)-diameter swivel plate casters—two with brakes.
- 1" (25mm)-diameter handle welded to angle legs.
- Corrosion- and stain-resistant.
- Polished stainless steel finish allows for ease of cleaning and sanitation.
- 500-lb. (226.8 kg) weight capacity.

### EAGLE GROUP

100 Industrial Boulevard, Clayton, DE 19938-8903 USA  
Phone: 302-653-3000 • 800-441-8440 • Fax: 302-653-2065  
www.eaglegrp.com  
www.eaglehmc.com

For custom configuration or fabrication needs, contact our **SpecFAB®** Division.  
Phone: 302-653-3000 • Fax: 302-653-2065 • e-mail: quotes@eaglegrp.com

### Certifications / Approvals



AutoQuotes





Item No.: \_\_\_\_\_  
 Project No.: \_\_\_\_\_  
 S.I.S. No.: \_\_\_\_\_

# Stainless Steel Utility Carts

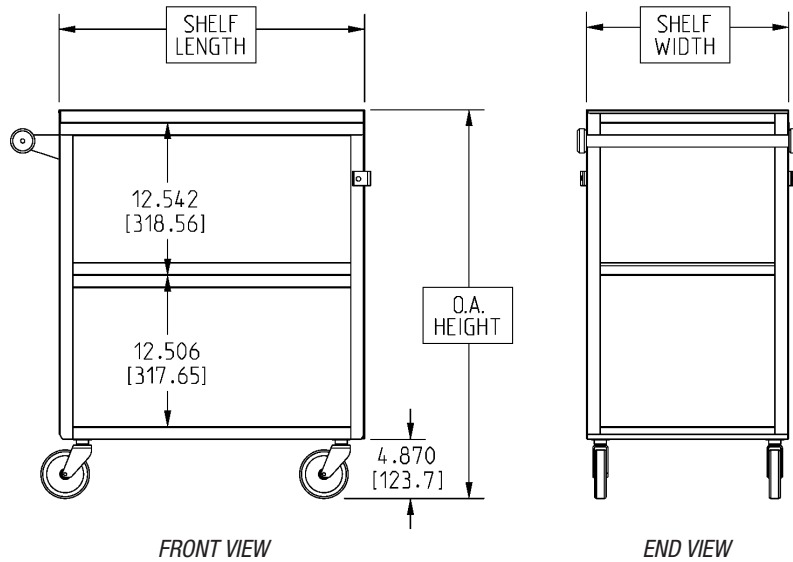
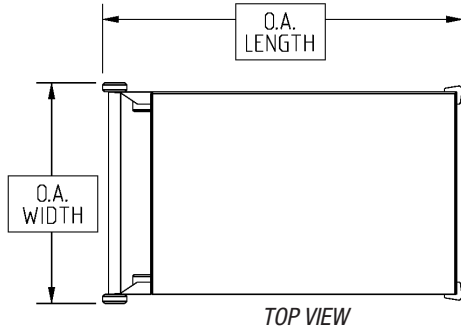

overall width x length x height		shelf width x length (inner dimensions)		shelf clearance		weight		with * Standard Upturns	with Upturn on all sides of all shelves
in.	mm	in.	mm	in.	mm	lbs.	kg	model #	model #
16 <sup>3</sup> / <sub>4</sub> " x 29 <sup>5</sup> / <sub>8</sub> " x 32"	426 x 753 x 813	16 <sup>1</sup> / <sub>2</sub> " x 25 <sup>5</sup> / <sub>16</sub> "	419 x 643	12 <sup>1</sup> / <sub>2</sub> "	318	95	43.1	UC-311	UUC-311
19" x 33" x 32"	483 x 838 x 813	18 <sup>3</sup> / <sub>4</sub> " x 28 <sup>1</sup> / <sub>16</sub> "	476 x 729	12 <sup>1</sup> / <sub>2</sub> "	318	95	43.1	UC-322	UUC-322

\* Upturn on sides and rear of top and center shelves.

**EAGLE GROUP**  
 100 Industrial Boulevard, Clayton, DE 19938-8903 USA  
 Phone: 302-653-3000 or 800-441-8440 • Fax: 302-653-2065  
 www.eaglegrp.com • www.eaglehmc.com

Printed in U.S.A.  
 ©2024 by Eagle Group

Rev. 03/24

Spec sheets available for viewing, printing or downloading from our online literature library at our websites

Although every attempt has been made to ensure the accuracy of the information provided, we cannot be held responsible for typographical or printing errors. Information and specifications are subject to change without notice. Please confirm at time of order.