



Material Handling, Healthcare & Cleanroom Equipment

Phone: (800) 441-8440 • (302) 653-3000

FAX: (302) 653-2065

Product Announcement

Short Form Specifications

Eagle Group Laboratory Exhaust Canopies, model # _____.
Island or wall mount exhaust canopies feature 16 gauge type 304 stainless steel construction, fully welded seams, polished interior and exterior, steel rod suspension brackets, full perimeter condensation edge, and integral 8"-diameter duct collar. Exhaust canopies are available in 30" and 36" depths, and widths ranging from 36" to 96".

Item #: _____
Model #: _____
Project #: _____
SIS #: _____

EG8226 Rev. 05/24

New Laboratory Exhaust Canopies

Design & Construction Features:

- 16-gauge type 304 stainless steel construction
- Fully welded seams
- Polished interior and exterior
- Integrated suspension brackets
- 8"-diameter x 2"-tall duct collar
- Full-perimeter condensation edge
- 30" and 36" depths
- 36", 48", 60", 72", 84" and 96" widths



island hood

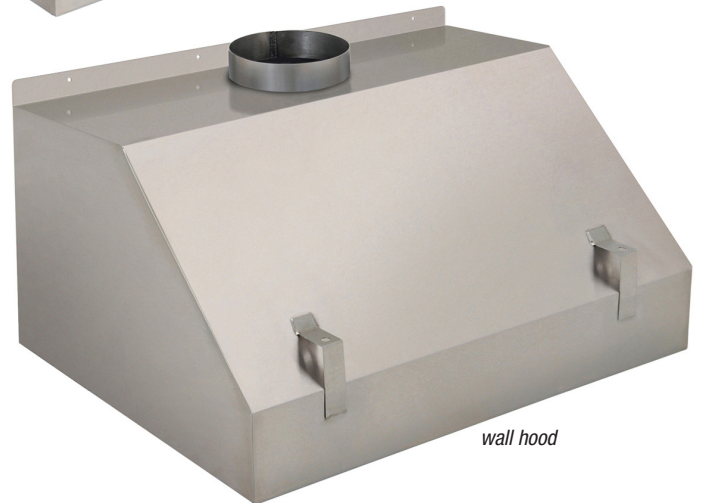

wall hood

Eagle's NEW Laboratory Exhaust Canopies are ideal for exhausting steam, odors, heat etc. Features the strength and beauty of 16 gauge type 304 stainless steel construction. Integral steel rod suspension brackets. 8"-diameter duct collar. Choose between wall and island units, 30" and 36" depths.

For custom configuration or fabrication needs, contact our **SpecFAB® Division**.

Phone: (302) 653-3000. FAX: (302) 653-2065.

E-mail: quotes@eaglegrp.com



Laboratory Exhaust Canopies

Island models

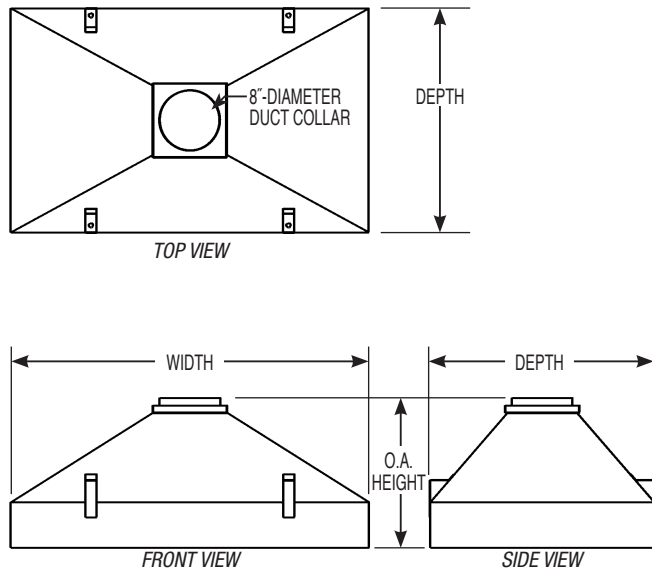

Wall models

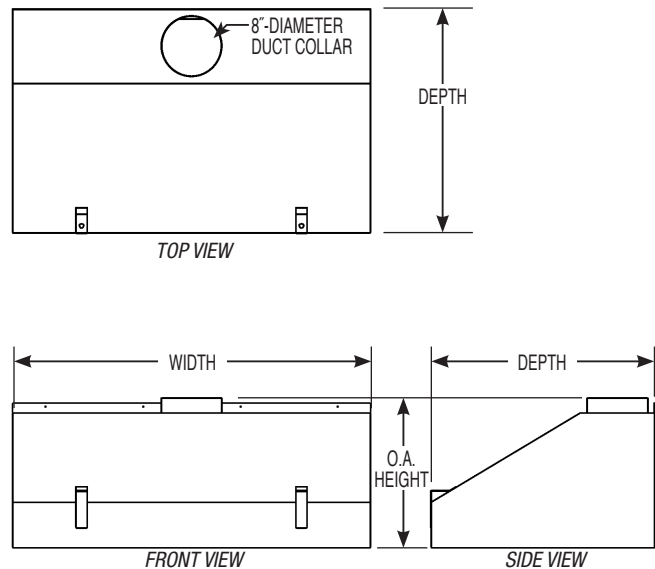

Island models				Wall models			
depth		width		overall height*		overall height*	
in.	mm	in.	mm	in.	mm	in.	mm
30"	762	36"	914	19"	483	20"	508
30"	762	48"	1219	19"	483	20"	508
30"	762	60"	1524	19"	483	20"	508
30"	762	72"	1829	19"	483	20"	508
30"	762	84"	2133	19"	483	20"	508
30"	762	96"	2438	19"	483	20"	508
36"	914	36"	914	19"	483	20"	508
36"	914	48"	1219	19"	483	20"	508
36"	914	60"	1524	19"	483	20"	508
36"	914	72"	1829	19"	483	20"	508
36"	914	84"	2133	19"	483	20"	508
36"	914	96"	2438	19"	483	20"	508

* Height includes 2" tall duct collar.