



Profit from the Eagle Advantage®

Specification Sheet

Short Form Specifications

Eagle Hand Sink, model _____. Constructed of all-welded type 304 stainless steel, with deep-drawn positive drain sink bowl, basket drain, inverted "V" edge to prevent spillage, and splash mounted gooseneck spout. Offered are the following hand sinks:

- Eagle Pedestal Style Hand Sink, model HSA-10-FA-P. Includes stainless steel pedestal base with front access panel, foot valves, p-trap and tail piece.
- Eagle Single Foot Valve Pedestal Style Hand Sink, model HSA-10-FA-1P. Includes stainless steel pedestal base with front access panel, single foot valve, P-trap and tail piece.
- Eagle Knee Pedal Hand Sink, model HSA-10-FK. Includes knee pedals and stainless steel skirt.
- Eagle Knee Pedal Hand Sink, model HSA-10-FKP. Includes single pedal knee valve and stainless steel skirt.
- Eagle Single Knee Pedal Hand Sink, model HSA-10-1FK. Includes single knee pedal and stainless steel skirt.
- Eagle Knee Pedal Hand Sink, model HSA-10-FDPK. Includes knee pedals, towel dispenser and soap dispenser.



HSA-10-FA-P
foot valve-operated
hand sink



HSA-10-FK
knee valve-operated hand sink



HSA-10-FKP

EAGLE GROUP

100 Industrial Boulevard, Clayton, DE 19938-8903 USA
Phone: 302-653-3000 • 800-441-8440 • Fax: 302-653-2065
www.eaglegrp.com
www.eaglehmc.com

For custom configuration or fabrication needs, contact our SpecFAB® Division.
Phone: 302-653-3000 • Fax: 302-653-2065 • e-mail: quotes@eaglegrp.com

Spec sheets available for viewing, printing or downloading from our online literature library at our websites

Eagle Foodservice Equipment, Eagle MHC, and SpecFAB® are divisions of Eagle Group. ©2024 by the Eagle Group

Item No.: _____
 Project No.: _____
 S.I.S. No.: _____

Knee/Foot Valve Operated Hand Sinks

MODELS:

- HSA-10-FK
- HSA-10-FDKP
- HSA-10-FKP
- HSA-10-FA-P
- HSA-10-1FK
- HSA-10-FA-1P

Design and Construction Features on all sinks

- Type 304 stainless steel all-welded construction.
- Splash mount lead-free gooseneck spout.
- 1½" basket drain.
- Inverted "V" edge rim retards spillage.
- Deep-drawn bowl with positive drainage.

Knee Valve-Operated Hand Sinks

- Model #HSA-10-FK includes individual hot & cold knee pedals.
- Model #HSA-10-FKP includes single pedal knee valve.
- Model #HSA-10-1FK comes with single knee pedal.
- Model #HSA-10-FDPK includes knee pedals, c-fold towel dispenser and soap dispenser.
- Stainless steel "skirt" on all knee valve operated hand sinks.
- Knee valve requires piping from valve to gooseneck.

Foot Valve-Operated Hand Sinks

- Stainless steel pedestal, complete with removable front access panel, mounts to floor and wall.
- Includes splash-mount lead-free gooseneck spout, foot pedal valves, p-trap, and tailpiece.
- Model #HSA-10-FA-1P comes with single foot pedal.
- Foot valve requires piping from valve to gooseneck.

Options / Accessories

- P-trap*
- Tail piece*
- MICROGARD® antimicrobial protection**

* For knee valve-operated handsinks

** See the Price List for more details about MICROGARD® for handsinks.

All Eagle Group hand sinks use lead-free faucets to meet California law #AB1953.

Certifications / Approvals



AutoQuotes



EG20.44 Rev. 06/24



Profit from the Eagle Advantage®

Item No.: _____
 Project No.: _____
 S.I.S. No.: _____

Knee-Operated Wall-Mounted Units

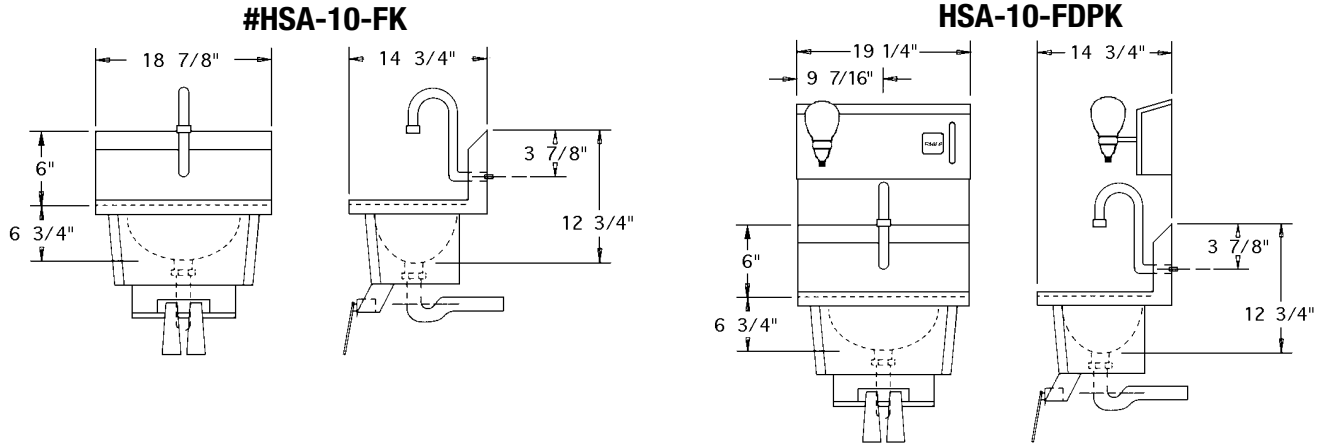

model #	includes	bowl size		overall size		weight	
		width in.	length x depth mm	width in.	length x height mm	lbs.	kg
HSA-10-FK	spout, knee pedals, skirt, basket drain	9 ³ / ₄ "	13 ¹ / ₂ " x 6 ³ / ₄ "	248 x 343 x 173	14 ³ / ₄ " x 18 ⁷ / ₈ " x 17 ¹ / ₂ "	376 x 480 x 445	27 12.2
HSA-10-FKP	spout, single pedal knee valve, skirt, basket drain	9 ³ / ₄ "	13 ¹ / ₂ " x 6 ³ / ₄ "	248 x 343 x 173	14 ³ / ₄ " x 18 ⁷ / ₈ " x 17 ¹ / ₂ "	376 x 480 x 445	26 11.8
HSA-10-1FK	spout, single knee pedal, skirt, basket drain	9 ³ / ₄ "	13 ¹ / ₂ " x 6 ³ / ₄ "	248 x 343 x 173	14 ³ / ₄ " x 18 ⁷ / ₈ " x 17 ¹ / ₂ "	376 x 480 x 445	27 12.2
HSA-10-FDPK	spout, knee pedals, skirt, soap disp., towel disp., basket drain	9 ³ / ₄ "	13 ¹ / ₂ " x 6 ³ / ₄ "	248 x 343 x 173	14 ³ / ₄ " x 19 ¹ / ₄ " x 33"	376 x 489 x 838	44 20.0

Foot-Operated Pedestal Units

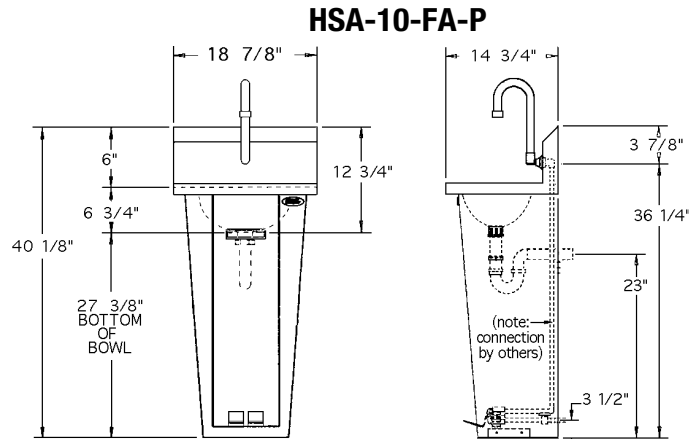

model #	includes	bowl size		overall size		weight	
		width in.	length x depth mm	width in.	length x height mm	lbs.	kg
HSA-10-FA-P	spout, foot pedals, p-trap, tail piece, basket drain	9 ³ / ₄ "	13 ¹ / ₂ " x 6 ³ / ₄ "	248 x 343 x 173	14 ³ / ₄ " x 18 ⁷ / ₈ " x 40 ¹ / ₈ "	376 x 480 x 1019	32 14.5
HSA-10-FA-1P	spout, single foot pedal, p-trap, tail piece, basket drain	9 ³ / ₄ "	13 ¹ / ₂ " x 6 ³ / ₄ "	248 x 343 x 173	14 ³ / ₄ " x 18 ⁷ / ₈ " x 40 ¹ / ₈ "	376 x 480 x 1019	32 14.5

EAGLE GROUP

100 Industrial Boulevard, Clayton, DE 19938-8903 USA

Phone: 302-653-3000 or 800-441-8440 • Fax: 302-653-2065

www.eaglegrp.com • www.eaglehmc.com

Printed in U.S.A.
 ©2024 by Eagle Group

Rev. 06/24

Spec sheets available for viewing, printing or downloading from our online literature library at our websites

Although every attempt has been made to ensure the accuracy of the information provided, we cannot be held responsible for typographical or printing errors. Information and specifications are subject to change without notice. Please confirm at time of order.