



Profit from the Eagle Advantage®

Specification Sheet

Short Form Specifications

Eagle Hand Sink with Built-In Waste Receptacle, model #HSA-10-FDP-T. Sink bowl to be deep-drawn for positive drainage, type 304 stainless steel—9¾" x 13½" x 6¾" deep. Splash mounted gooseneck faucet, basket drain, stainless steel sink skirt, stainless steel waste receptacle with handle, and soap & towel dispenser. Towel dispenser to have hinged top assembly with cam style lock and two key, and is designed to accommodate 4" x 10" C-fold paper towels.



PATENTED DESIGN

Model HSA-10-FDP-T
(Patent No. 5,732,422)

Options / Accessories

MICROGARD® antimicrobial agent*

* See Product Announcement #EG8135 for more details about MICROGARD® for Hand Sinks.

Item No.: _____
Project No.: _____
S.I.S. No.: _____

Hand Sink with Built-In Waste Receptacle

MODELS:

HSA-10-FDP-T

Design & Construction Features

- All 304 stainless steel construction.
- Inverted "V" edge rim retards spillage.
- All-welded towel dispenser features a hinged top assembly, sight window to visually inspect towel level, quick-fill soap dispenser, and is designed to accommodate 4" x 10" (102 x 254mm) C-fold disposable paper towels.
- Towel dispenser features a cam style lock and two keys.
- Heavy gauge stainless steel built-in waste receptacle that slides onto the bottom of the waste skirt.
- 4" x 6" (102 x 152mm) trash opening which features a protective edge trim strip.
- Waste receptacle features integrated full-length front handle.
- One-piece, deep-drawn, seamless bowl for positive drain.
- Splash mounted gooseneck faucet.
- Basket drain.

EAGLE GROUP

100 Industrial Boulevard, Clayton, DE 19938-8903 USA
Phone: 302-653-3000 • 800-441-8440 • Fax: 302-653-2065
www.eaglegrp.com
www.eaglemhc.com

For custom configuration or fabrication needs, contact our SpecFAB® Division.
Phone: 302-653-3000 • Fax: 302-653-2065 • e-mail: quotes@eaglegrp.com





Item No.: _____
 Project No.: _____
 S.I.S. No.: _____

Hand Sink with Built-In Waste Receptacle

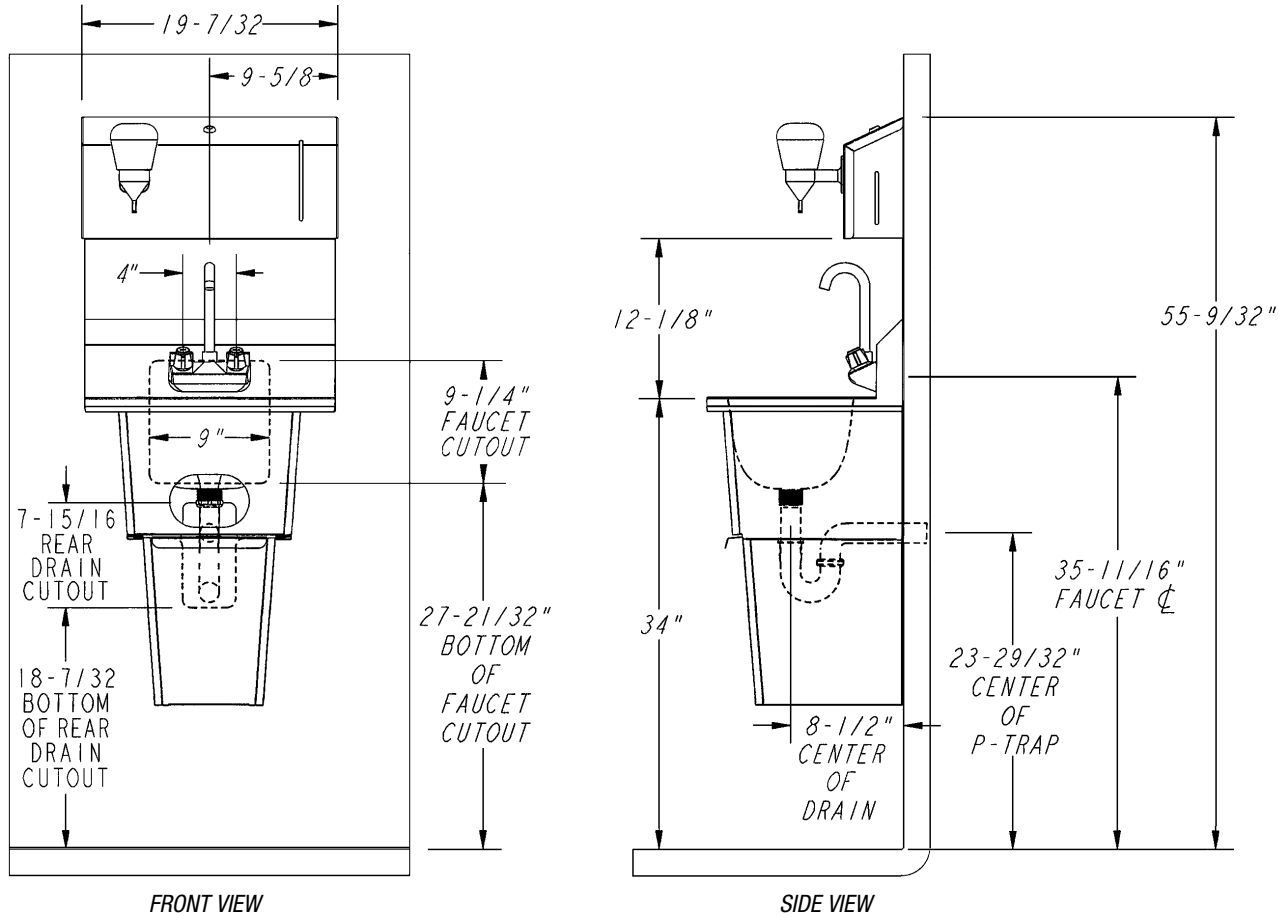

model #	bowl size		overall size		weight	
	width in.	length x depth mm	width in.	length x height mm	lbs.	kg
HSA-10-FDP-T	9 3/4"	13 1/2" x 6 3/4"	343 x 248 x 173	14 3/4" x 19 1/4" x 44 5/8"	29	13.2

EAGLE GROUP
 100 Industrial Boulevard, Clayton, DE 19938-8903 USA
 Phone: 302-653-3000 or 800-441-8440 • Fax: 302-653-2065
 www.eaglegrp.com • www.eaglemhc.com

Printed in U.S.A.
 ©2024 by Eagle Group
 Rev. 06/24

Spec sheets available for viewing, printing or downloading from our online literature library at our websites

Although every attempt has been made to ensure the accuracy of the information provided, we cannot be held responsible for typographical or printing errors. Information and specifications are subject to change without notice. Please confirm at time of order.