



Profit from the Eagle Advantage®

Specification Sheet

Short Form Specifications

Eagle One-Compartment Utility Sinks, model _____ . Constructed of type 304 or 430 stainless steel with square corners, Euro-Style edging on front, and 8" backsplash. All partitions have 5/8" rolled top edge. Faucet holes punched on 8" centers. All outside corners to be bullnosed for clean, safe edges. 1 1/8" O.D. galvanized tubular legs with adjustable bullet feet.



one-compartment utility sink

Options / Accessories

- Faucets
- Detachable drainboard *
- Lever waste
- Lever waste with overflow
- Stainless steel legs
- Stainless steel feet

* See Spec Sheet #EG20.13E for optional detachable drainboards.

Design and Construction Features:

- For numerous applications when NSF approval is not required (For NSF-approved utility sinks, add prefix "N-" to model number. Example: N-2424-1-16/3)
- Entire assembly is fuse welded and planished, providing a one-piece seamless sink unit.
- 34 1/2" to 35 1/2" (876 to 902mm) working height.

EAGLE GROUP

100 Industrial Boulevard, Clayton, DE 19938-8903 USA
 Phone: 302-653-3000 • 800-441-8440 • Fax: 302-653-2065
 www.eaglegrp.com
 www.eaglehmc.com

For custom configuration or fabrication needs, contact our SpecFAB® Division.
 Phone: 302-653-3000 • Fax: 302-653-2065 • e-mail: quotes@eaglegrp.com

Item No.: _____
 Project No.: _____
 S.I.S. No.: _____

One-Compartment Utility Sinks with Square Corner Construction

MODELS:

- 1818-1-16/4
- 1818-1-16/3
- 1824-1-16/4
- 1824-1-16/3
- 2118-1-16/4
- 2118-1-16/3
- 2124-1-16/4
- 2124-1-16/3
- 2136-1-16/4
- 2136-1-16/3
- 2424-1-16/4
- 2424-1-16/3
- 2424-1-18-16/3
- 2424-1-24-16/4
- 2424-1-24-16/3

Top:

- All partitions have euro-style front edge.
- Available with detachable* or welded drainboards.
- 8" (203mm) splash features 2" (51mm) return to wall on 45° angle, with 1" (25mm) upturn.
- 1 1/8" (29mm) faucet holes punched on 8" (203mm) centers.

Legs:

- 1 1/8" (41mm)-diameter heavy-gauge galvanized tubing.
- High-impact corrosion-resistant 1" (25mm) adjustable bullet feet.
- Leg locations fall directly under sink bowl, providing increased stability and maximum weight support.

Sink Bowl:

- 16 gauge type 304 or 430 stainless steel.
- 13 3/8" (340mm)-deep compartment.
- 12-gauge leg gussets welded to a die-cut heavy-gauge reinforcing plate underneath sink bowl.
- Drain hole is 3 1/2" (89mm)-diameter, recessed, and complete with 1 1/2" (38mm) IPS basket-type waste drain, which is shipped loose.





Item No.: _____
 Project No.: _____
 S.I.S. No.: _____

One-Compartment Utility Sinks with Square Corner Construction

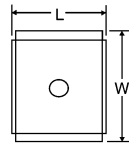
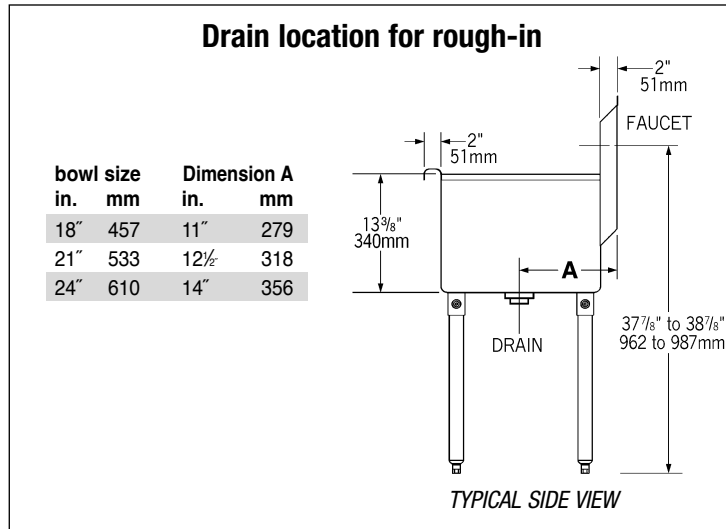

Sinks with No Drainboards

16 gauge type 430 stainless steel model #	16 gauge type 304 stainless steel model #	BOWL DIMENSIONS				DRAINBOARD		OVERALL DIMENSIONS				weight	
		width in.	width mm	length in.	length mm	quantity	length in. mm	width in.	width mm	length in.	length mm	lbs.	kg
1818-1-16/4	1818-1-16/3	18"	457	18"	457	0	n/a	22"	559	19 1/2"	492	53	24.0
1824-1-16/4	1824-1-16/3	18"	457	24"	610	0	n/a	22"	559	25 1/2"	645	56	25.4
2118-1-16/4	2118-1-16/3	21"	533	18"	457	0	n/a	25"	635	19 1/2"	492	56	25.4
2124-1-16/4	2124-1-16/3	21"	533	24"	610	0	n/a	25"	635	25 1/2"	645	61	27.7
2136-1-16/4	2136-1-16/3	21"	533	36"	914	0	n/a	25"	635	37 1/2"	949	66	29.9
2424-1-16/4	2424-1-16/3	24"	610	24"	610	0	n/a	28"	711	25 1/2"	645	60	27.2
2436-1-16/4	2436-1-16/3	24"	610	36"	914	0	n/a	28"	711	37 1/2"	949	68	30.8

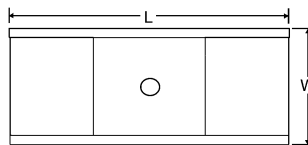

Sinks with Double Drainboards

16 gauge type 430 stainless steel model #	16 gauge type 304 stainless steel model #	BOWL DIMENSIONS				DRAINBOARD		OVERALL DIMENSIONS				weight	
		width in.	width mm	length in.	length mm	quantity	length in. mm	width in.	width mm	length in.	length mm	lbs.	kg
2124-1-18-16/4	2124-1-18-16/3	21"	533	24"	610	2	18" 457	25"	635	60 1/4"	1530	99	44.9
2424-1-24-16/4	2424-1-24-16/3	24"	610	24"	610	2	24" 610	28"	711	72 1/4"	1835	108	49.0

EAGLE GROUP

100 Industrial Boulevard, Clayton, DE 19938-8903 USA
 Phone: 302-653-3000 or 800-441-8440 • Fax: 302-653-2065
 www.eaglegrp.com • www.eaglemhc.com

Printed in U.S.A.
 ©2024 by Eagle Group

Rev. 06/24

Spec sheets available for viewing, printing or downloading from our online literature library at our websites

Although every attempt has been made to ensure the accuracy of the information provided, we cannot be held responsible for typographical or printing errors. Information and specifications are subject to change without notice. Please confirm at time of order.



Profit from the Eagle Advantage®

Specification Sheet

Short Form Specifications

Eagle Two-Compartment Utility Sinks, model _____ . Constructed of type 304 or 430 stainless steel with square corners, Euro-Style edging on front, and 8" backsplash. All partitions have 5/8" rolled top edge. Faucet holes punched on 8" centers. All outside corners to be bullnosed for clean, safe edges. 1 1/2" O.D. galvanized tubular legs with adjustable bullet feet.



two-compartment utility sink

Options / Accessories

- Faucets
- Detachable drainboard *
- Lever waste
- Lever waste with overflow
- Stainless steel legs
- Stainless steel feet

* See Spec Sheet #EG20.13E for optional detachable drainboards.

Design and Construction Features:

- For numerous applications when NSF approval is not required (For NSF-approved utility sinks, add prefix "N-" to model number. Example: N-2460-2-16/3)
- Entire assembly is fuse welded and planished, providing a one-piece seamless sink unit.
- 34 1/2" to 35 1/2" (876 to 902mm) working height.

EAGLE GROUP

100 Industrial Boulevard, Clayton, DE 19938-8903 USA
 Phone: 302-653-3000 • 800-441-8440 • Fax: 302-653-2065
 www.eaglegrp.com
 www.eaglehmc.com

For custom configuration or fabrication needs, contact our SpecFAB® Division.
 Phone: 302-653-3000 • Fax: 302-653-2065 • e-mail: quotes@eaglegrp.com

Item No.: _____
 Project No.: _____
 S.I.S. No.: _____

Two-Compartment Utility Sinks with Square Corner Construction

MODELS:

- 1836-2-16/4
- 1836-2-16/3
- 1848-2-16/4
- 1848-2-16/3
- 2136-2-16/4
- 2136-2-16/3
- 2148-2-16/4
- 2148-2-16/3
- 2448-2-16/4
- 2448-2-16/3
- 2460-2-16/4
- 2460-2-16/3
- 2136-2-18-16/4
- 2136-2-18-16/3
- 2448-2-24-16/4
- 2448-2-24-16/3

Top:

- All partitions have euro-style front edge.
- Available with detachable* or welded drainboards.
- 8" (203mm) splash features 2" (51mm) return to wall on 45° angle, with 1" (25mm) upturn.
- 1 1/8" (29mm) faucet holes punched on 8" (203mm) centers.

Legs:

- 1 1/2" (41mm)-diameter heavy-gauge galvanized tubing.
- High-impact corrosion-resistant 1" (25mm) adjustable bullet feet.
- Leg locations fall directly under sink bowls, providing increased stability and maximum weight support.

Sink Bowls:

- 16 gauge type 304 or 430 stainless steel.
- 13 3/8" (340mm)-deep compartments.
- 12-gauge leg gussets welded to a die-cut heavy-gauge reinforcing plate underneath sink bowls.
- Drain holes are 3 1/2" (89mm)-diameter, recessed, and complete with 1 1/2" (38mm) IPS basket-type waste drain, which is shipped loose.





Item No.: _____
 Project No.: _____
 S.I.S. No.: _____

Two-Compartment Utility Sinks with Square Corner Construction

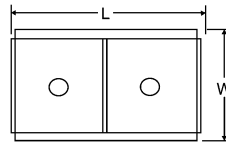
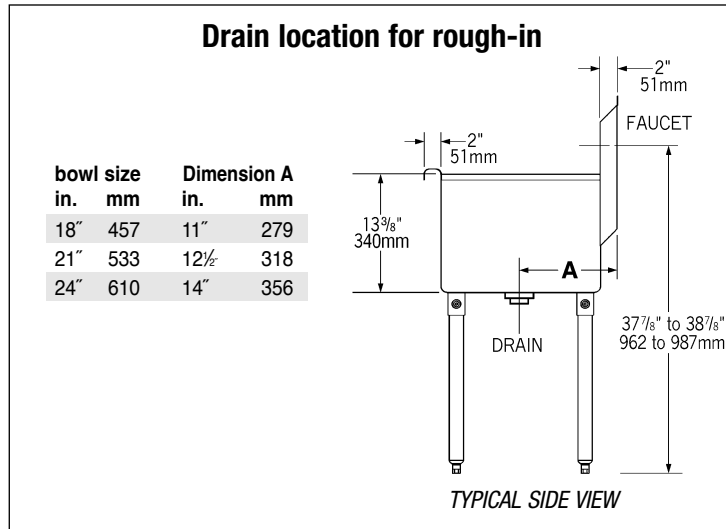

Sinks with No Drainboards

16 gauge type 430 stainless steel model #	16 gauge type 304 stainless steel model #	BOWL DIMENSIONS				DRAINBOARD			OVERALL DIMENSIONS				weight	
		width		length		quantity	length		width		length		lbs.	kg
in.	mm	in.	mm	in.	mm		in.	mm	in.	mm	in.	mm		
1836-2-16/4	1836-2-16/3	18"	457	18"	457	0	n/a	22"	559	37½"	991	75	34.0	
1848-2-16/4	1848-2-16/3	18"	457	24"	610	0	n/a	22"	559	49½"	1295	80	36.3	
2136-2-16/4	2136-2-16/3	21"	533	18"	457	0	n/a	25"	635	37½"	991	80	36.3	
2148-2-16/4	2148-2-16/3	21"	533	24"	610	0	n/a	25"	635	49½"	1295	85	38.6	
2448-2-16/4	2448-2-16/3	24"	610	24"	610	0	n/a	28"	711	49½"	1295	89	40.4	
2460-2-16/4	2460-2-16/3	24"	610	30"	762	0	n/a	28"	711	61½"	1600	95	43.1	

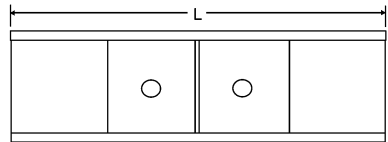

Sinks with Double Drainboards

16 gauge type 430 stainless steel model #	16 gauge type 304 stainless steel model #	BOWL DIMENSIONS				DRAINBOARD			OVERALL DIMENSIONS				weight	
		width		length		quantity	length		width		length		lbs.	kg
in.	mm	in.	mm	in.	mm		in.	mm	in.	mm	in.	mm		
2136-2-18-16/4	2136-2-18-16/3	21"	533	18"	457	2	18"	457	25"	635	72¼"	1905	120	54.4
2448-2-24-16/4	2448-2-24-16/3	24"	610	24"	610	2	24"	610	28"	711	96¼"	2515	139	63.1

EAGLE GROUP

100 Industrial Boulevard, Clayton, DE 19938-8903 USA
 Phone: 302-653-3000 or 800-441-8440 • Fax: 302-653-2065
 www.eaglegrp.com • www.eaglemhc.com

Printed in U.S.A.
 ©2024 by Eagle Group

Rev. 06/24

Spec sheets available for viewing, printing or downloading from our online literature library at our websites

Although every attempt has been made to ensure the accuracy of the information provided, we cannot be held responsible for typographical or printing errors. Information and specifications are subject to change without notice. Please confirm at time of order.



Profit from the Eagle Advantage®

Specification Sheet

Short Form Specifications

Eagle Three-Compartment Utility Sinks, model _____ . Constructed of type 304 or 430 stainless steel with square corners, Euro-Style edging on front, and 8" backsplash. All partitions have 5/8" rolled top edge. Faucet holes punched on 8" centers. All outside corners to be bullnosed for clean, safe edges. 1 1/2" O.D. galvanized tubular legs with adjustable bullet feet.



three-compartment utility sink

Options / Accessories

- Faucets
- Detachable drainboard *
- Lever waste
- Lever waste with overflow
- Stainless steel legs
- Stainless steel feet

* See Spec Sheet #EG20.13E for optional detachable drainboards.

Design and Construction Features:

- For numerous applications when NSF approval is not required (For NSF-approved utility sinks, add prefix "N-" to model number. Example: N-2460-3-16/3)
- Entire assembly is fuse welded and planished, providing a one-piece seamless sink unit.
- 34 1/2" to 35 1/2" (876 to 902mm) working height.

EAGLE GROUP

100 Industrial Boulevard, Clayton, DE 19938-8903 USA
 Phone: 302-653-3000 • 800-441-8440 • Fax: 302-653-2065
 www.eaglegrp.com
 www.eaglehmc.com

For custom configuration or fabrication needs, contact our SpecFAB® Division.
 Phone: 302-653-3000 • Fax: 302-653-2065 • e-mail: quotes@eaglegrp.com

Item No.: _____
 Project No.: _____
 S.I.S. No.: _____

Three-Compartment Utility Sinks with Square Corner Construction

MODELS:

- 1836-3-16/4
- 1836-3-16/3
- 1848-3-16/4
- 1848-3-16/3
- 1854-3-16/4
- 1854-3-16/3
- 2136-3-16/3
- 2148-3-16/4
- 2154-3-16/4
- 2154-3-16/3
- 2160-3-16/4
- 2160-3-16/3
- 2448-3-16/4
- 2448-3-16/3
- 2460-3-16/4
- 2472-3-16/4
- 2472-3-16/3
- 2136-3-18-16/3
- 2148-3-18-16/4
- 2148-3-18-16/3
- 2154-3-18-16/4
- 2154-3-18-16/3
- 2472-3-24-16/4
- 2472-3-24-16/3

Top:

- All partitions have euro-style front edge.
- Available with detachable* or welded drainboards.
- 8" (203mm) splash features 2" (51mm) return to wall on 45° angle, with 1" (25mm) upturn.
- 1 1/8" (29mm) faucet holes punched on 8" (203mm) centers.

Legs:

- 1 1/2" (41mm)-diameter heavy-gauge galvanized tubing.
- High-impact corrosion-resistant 1" (25mm) adjustable bullet feet.
- Leg locations fall directly under sink bowls, providing increased stability and maximum weight support.

Sink Bowls:

- 16 gauge type 304 or 430 stainless steel.
- 13 3/8" (340mm)-deep compartments.
- 12-gauge leg gussets welded to a die-cut heavy-gauge reinforcing plate underneath sink bowls.
- Drain holes are 3 1/2" (89mm)-diameter recessed and complete with 1 1/2" (38mm) IPS basket-type waste drain, which is shipped loose.





Item No.: _____
 Project No.: _____
 S.I.S. No.: _____

Three-Compartment Utility Sinks with Square Corner Construction

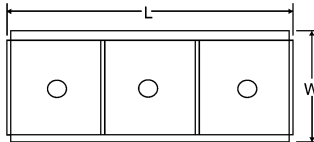
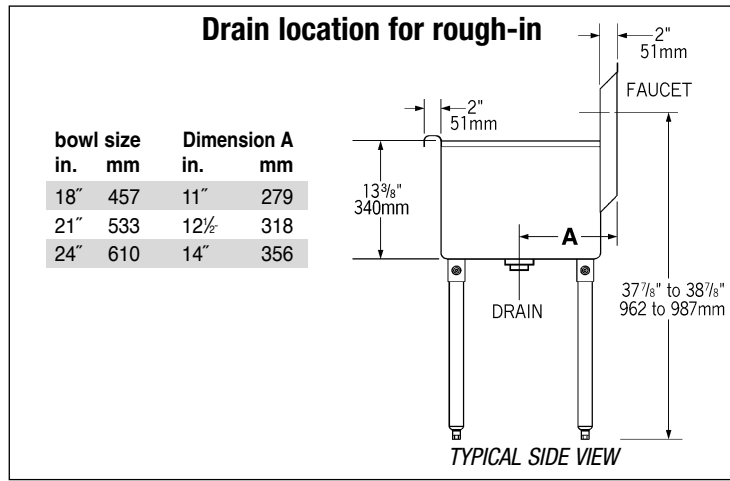

Sinks with No Drainboards

16 gauge type 430 stainless steel model #	16 gauge type 304 stainless steel model #	BOWL DIMENSIONS				DRAINBOARD		OVERALL DIMENSIONS				weight	
		width in.	width mm	length in.	length mm	quantity	length in. mm	width in.	width mm	length in.	length mm	lbs.	kg
1836-3-16/4	1836-3-16/3	18"	457	12"	305	0	n/a	22"	559	37¾"	949	79	35.8
1848-3-16/4	1848-3-16/3	18"	457	16"	406	0	n/a	22"	559	49¾"	1254	90	40.8
1854-3-16/4	1854-3-16/3	18"	457	18"	457	0	n/a	22"	559	55¾"	1406	97	44.0
2136-3-16/4	2136-3-16/3	21"	533	12"	305	0	n/a	25"	635	37¾"	949	85	38.6
2148-3-16/4	2148-3-16/3	21"	533	16"	406	0	n/a	25"	635	49¾"	1254	87	39.5
2154-3-16/4	2154-3-16/3	21"	533	18"	457	0	n/a	25"	635	55¾"	1406	100	45.4
2160-3-16/4*	2160-3-16/3*	21"	533	20"	508	0	n/a	25"	635	61¾"	1559	110	49.9
2448-3-16/4	2448-3-16/3	24"	610	16"	406	0	n/a	28"	711	49¾"	1254	92	41.7
2460-3-16/4*	2460-3-16/3*	24"	610	20"	508	0	n/a	28"	711	61¾"	1559	115	52.2
2472-3-16/4*	2472-3-16/3*	24"	610	24"	610	0	n/a	28"	711	73¾"	1864	125	56.7

* Includes two sets of faucet holes.

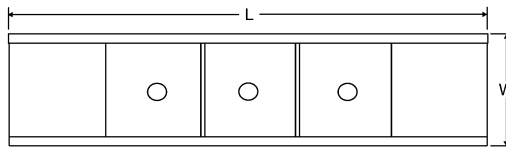

Sinks with Double Drainboards

16 gauge type 430 stainless steel model #	16 gauge type 304 stainless steel model #	BOWL DIMENSIONS				DRAINBOARD		OVERALL DIMENSIONS				weight	
		width in.	width mm	length in.	length mm	quantity	length in. mm	width in.	width mm	length in.	length mm	lbs.	kg
2136-3-18-16/4	2136-3-18-16/3	21"	533	12"	305	2	18" 457	25"	635	72¼"	1835	125	56.7
2148-3-18-16/4	2148-3-18-16/3	21"	533	16"	406	2	18" 457	25"	635	84¼"	2140	127	57.6
2154-3-18-16/4	2154-3-18-16/3	21"	533	18"	457	2	18" 457	25"	635	90¼"	2292	140	63.5
2472-3-24-16/4*	2472-3-24-16/3*	24"	610	24"	610	2	24" 610	28"	711	120¼"	3054	175	79.4

* Includes two sets of faucet holes.

EAGLE GROUP

100 Industrial Boulevard, Clayton, DE 19938-8903 USA
 Phone: 302-653-3000 or 800-441-8440 • Fax: 302-653-2065
 www.eaglegrp.com • www.eaglehmc.com

Printed in U.S.A.
 ©2024 by Eagle Group

Rev. 06/24

Spec sheets available for viewing, printing or downloading from our online literature library at our websites

Although every attempt has been made to ensure the accuracy of the information provided, we cannot be held responsible for typographical or printing errors. Information and specifications are subject to change without notice. Please confirm at time of order.



Profit from the Eagle Advantage®

Specification Sheet

Short Form Specifications

Eagle Four-Compartment Utility Sinks, model _____ . Constructed of type 304 or 430 stainless steel with square corners, Euro-Style edging on front, and 8" backsplash. All partitions have 5/8" rolled top edge. Faucet holes punched on 8" centers (set of two). All outside corners to be bullnosed for clean, safe edges. 1 1/8" O.D. galvanized tubular legs with adjustable bullet feet.



four-compartment utility sink

Options / Accessories

- Faucets
- Detachable drainboard *
- Lever waste
- Lever waste with overflow
- Stainless steel legs
- Stainless steel feet

* See Spec Sheet #EG20.13E for optional detachable drainboards.

Design and Construction Features:

- For numerous applications when NSF approval is not required (For NSF-approved utility sinks, add prefix "N-" to model number. Example: N-2460-2-16/3)
- Entire assembly is fuse welded and planished, providing a one-piece seamless sink unit.
- 34 1/2" to 35 1/2" (876 to 902mm) working height.

EAGLE GROUP

100 Industrial Boulevard, Clayton, DE 19938-8903 USA
 Phone: 302-653-3000 • 800-441-8440 • Fax: 302-653-2065
 www.eaglegrp.com
 www.eaglehmc.com

For custom configuration or fabrication needs, contact our SpecFAB® Division.
 Phone: 302-653-3000 • Fax: 302-653-2065 • e-mail: quotes@eaglegrp.com

Item No.: _____
 Project No.: _____
 S.I.S. No.: _____

Four-Compartment Utility Sinks with Square Corner Construction

MODELS:

- 1872-4-16/4
- 1872-4-16/3
- 2172-4-16/4
- 2172-4-16/3
- 2472-4-16/4
- 2472-4-16/3
- 2172-4-18-16/4
- 2172-4-18-16/3

Top:

- All partitions have euro-style front edge.
- Available with detachable* or welded drainboards.
- 8" (203mm) splash features 2" (51mm) return to wall on 45° angle, with 1" (25mm) upturn.
- Set of two 1 1/8" (29mm) faucet holes punched on 8" (203mm) centers.

Legs:

- 1 1/8" (41mm)-diameter heavy-gauge galvanized tubing.
- High-impact corrosion-resistant 1" (25mm) adjustable bullet feet.
- Leg locations fall directly under sink bowls, providing increased stability and maximum weight support.

Sink Bowls:

- 16 gauge type 304 or 430 stainless steel.
- 13 3/8" (340mm)-deep compartments.
- 12-gauge leg gussets welded to a die-cut heavy-gauge reinforcing plate underneath sink bowls.
- Drain holes are 3 1/2" (89mm)-diameter, recessed, and complete with 1 1/2" (38mm) IPS basket-type waste drain, which is shipped loose.





Item No.: _____
 Project No.: _____
 S.I.S. No.: _____

Four-Compartment Utility Sinks with Square Corner Construction

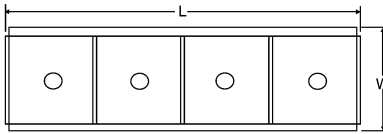
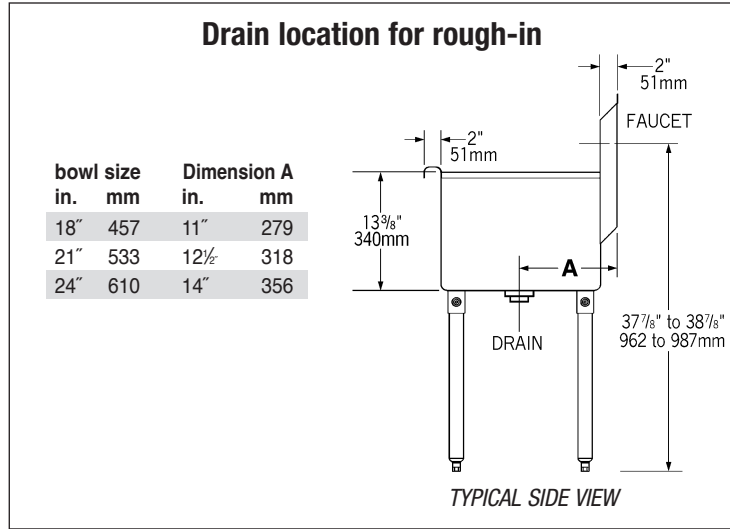

Sinks with No Drainboards

16 gauge type 430 stainless steel model #	16 gauge type 304 stainless steel model #	BOWL DIMENSIONS				DRAINBOARD			OVERALL DIMENSIONS				weight	
		width in.	width mm	length in.	length mm	quantity	length in.	length mm	width in.	width mm	length in.	length mm	lbs.	kg
1872-4-16/4	1872-4-16/3	18"	457	18"	457	0	n/a		22"	559	73 3/8"	1864	110	49.9
2172-4-16/4	2172-4-16/3	21"	533	18"	457	0	n/a		25"	635	73 3/8"	1864	115	52.2
2472-4-16/4	2472-4-16/3	24"	610	18"	457	0	n/a		28"	711	73 3/8"	1864	125	56.7

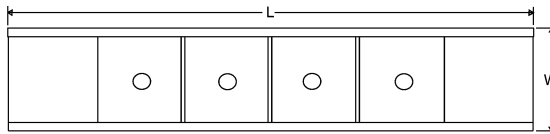

Sinks with Double Drainboards

16 gauge type 430 stainless steel model #	16 gauge type 304 stainless steel model #	BOWL DIMENSIONS				DRAINBOARD			OVERALL DIMENSIONS				weight	
		width in.	width mm	length in.	length mm	quantity	length in.	length mm	width in.	width mm	length in.	length mm	lbs.	kg
2172-4-18-16/4	2172-4-18-16/3	21"	533	18"	457	2	18"	457	25"	635	108 1/4"	2750	155	70.3

EAGLE GROUP
 100 Industrial Boulevard, Clayton, DE 19938-8903 USA
 Phone: 302-653-3000 or 800-441-8440 • Fax: 302-653-2065
 www.eaglegrp.com • www.eaglemhc.com

Printed in U.S.A.
 ©2024 by Eagle Group
 Rev. 06/24

Spec sheets available for viewing, printing or downloading from our online literature library at our websites

Although every attempt has been made to ensure the accuracy of the information provided, we cannot be held responsible for typographical or printing errors. Information and specifications are subject to change without notice. Please confirm at time of order.