

EL Series Solid Gowning Benches with Welded H-Frame

ASSEMBLY INSTRUCTIONS

CAUTION

INSPECT CONTENTS IMMEDIATELY AND FILE CLAIM WITH DELIVERING CARRIER FOR ANY DAMAGE. **SAVE YOUR BOX AND ALL PACKING MATERIALS.** YOU ARE RESPONSIBLE FOR DAMAGE TO YOUR UNIT IF RETURNED IMPROPERLY PACKED.

See reverse side for Units with Adjustable H-Frame.

Step 1 - Attach frame to seat.

- Lay seat upside down so that the gussets face upward.
Note: Take care not to scratch the finish.
- Insert legs into gussets.
- Tighten all screws.

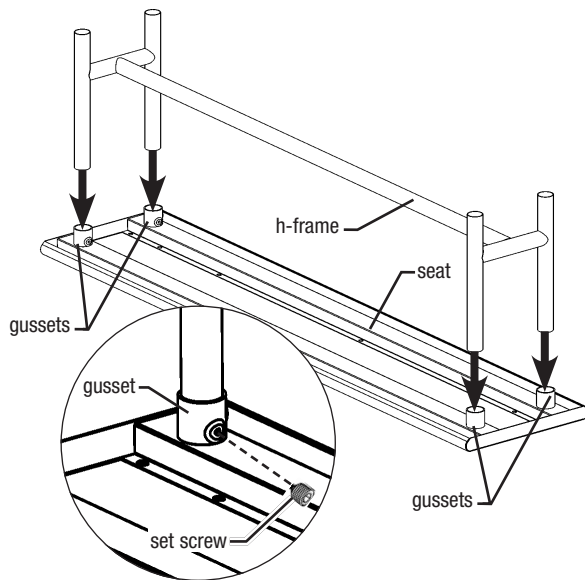

Step 2 - Assemble feet to bottom of legs.

- Use a rubber mallet to insert feet into legs.

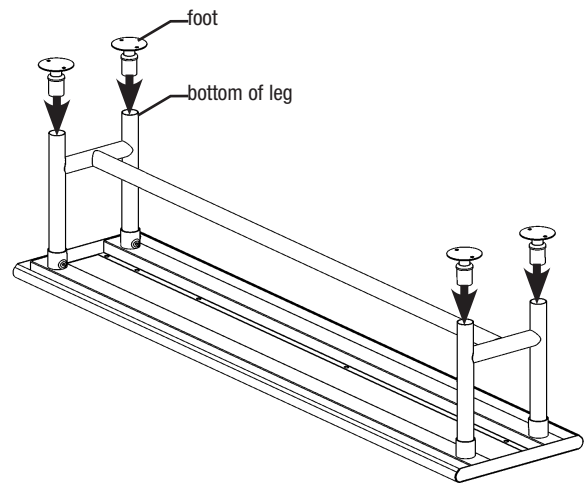

Step 3 - Flip the bench onto its feet.

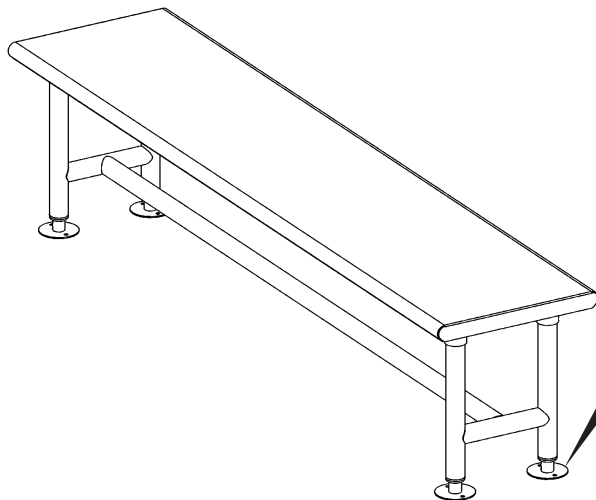

Step 4 - Secure feet to the floor.

Hardware not included.

Note: 96"-long units feature six (6) legs/feet.
All other lengths have four (4) legs.

Assembly is complete.



EG9928 Revised 12/24

EL Series Solid Gowning Benches with Adjustable H-Frame

ASSEMBLY INSTRUCTIONS

CAUTION

INSPECT CONTENTS IMMEDIATELY AND FILE CLAIM WITH DELIVERING CARRIER FOR ANY DAMAGE. **SAVE YOUR BOX AND ALL PACKING MATERIALS.** YOU ARE RESPONSIBLE FOR DAMAGE TO YOUR UNIT IF RETURNED IMPROPERLY PACKED.

See reverse side for Units with Welded H-Frame.

Step 1 - Assemble crossbrace subassembly.

- Assemble castings to end-to-end and front-to-back crossbracing, as shown.
- Tighten set screws in the appropriate threaded holes in castings (see below).

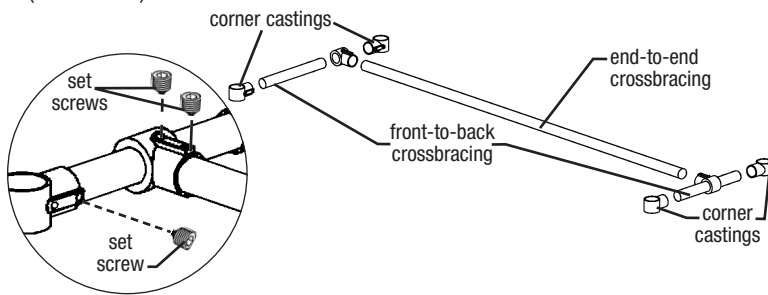

Step 2 - Attach crossbrace subassembly to legs.

- On legs, measure and mark desired height of crossbrace subassembly.
- Insert legs.
- Snug the set screws in the appropriate threaded hole in each casting (see below).

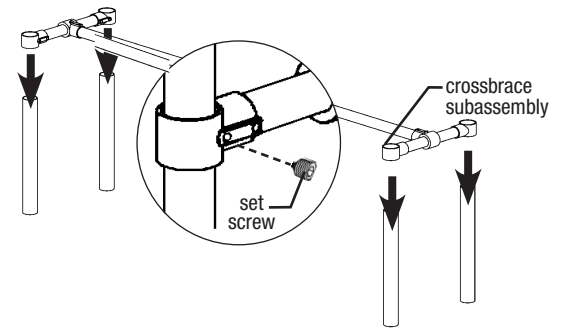

Step 3 - Assemble feet, legs, and seat.

- Lay seat upside down so that the gussets face upward.
Note: Take care not to scratch the finish.
- Insert legs into gussets.
- Use a rubber mallet to insert feet into legs.
- Tighten all screws.

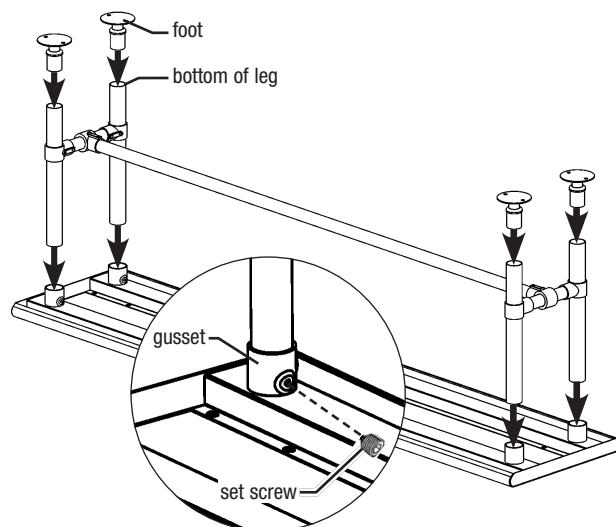

Step 4 - Flip the bench onto its feet.

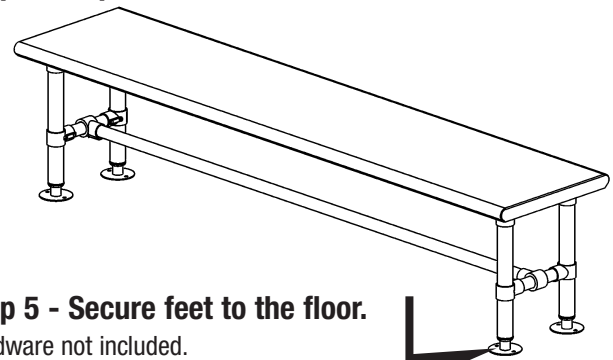

Step 5 - Secure feet to the floor.

- Hardware not included.
- Note: 96"-long units feature six (6) legs/feet. All other lengths have four (4) legs.
- Assembly is complete.

(End)

CARE AND CLEANING

CLICK HERE
for full
information sheet

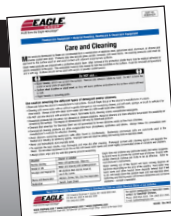

• 100 Industrial Boulevard, Clayton, Delaware 19938-8903 U.S.A.
• Phone: 302/653-3000 • 800/441-8440 • Fax: 302/653-2065
• www.eaglegrp.com • www.eaglehmc.com

Eagle Foodservice Equipment, Eagle MHC, and SpecFAB® are divisions of Eagle Group. ©2024 by the Eagle Group