

# Heavy Duty Linen Carts

## ASSEMBLY INSTRUCTIONS

### CAUTION

INSPECT CONTENTS IMMEDIATELY AND FILE CLAIM WITH DELIVERING CARRIER FOR ANY DAMAGE. **SAVE YOUR BOX AND ALL PACKING MATERIALS.** YOU ARE RESPONSIBLE FOR DAMAGE TO YOUR UNIT IF RETURNED IMPROPERLY PACKED.

Thank you for your purchase. Before assembly, read this instruction sheet carefully. After reading, be sure to store this instruction in a safe place, should it be needed for future reference.

### Step 1 - Attach posts to frame, using leveling feet.

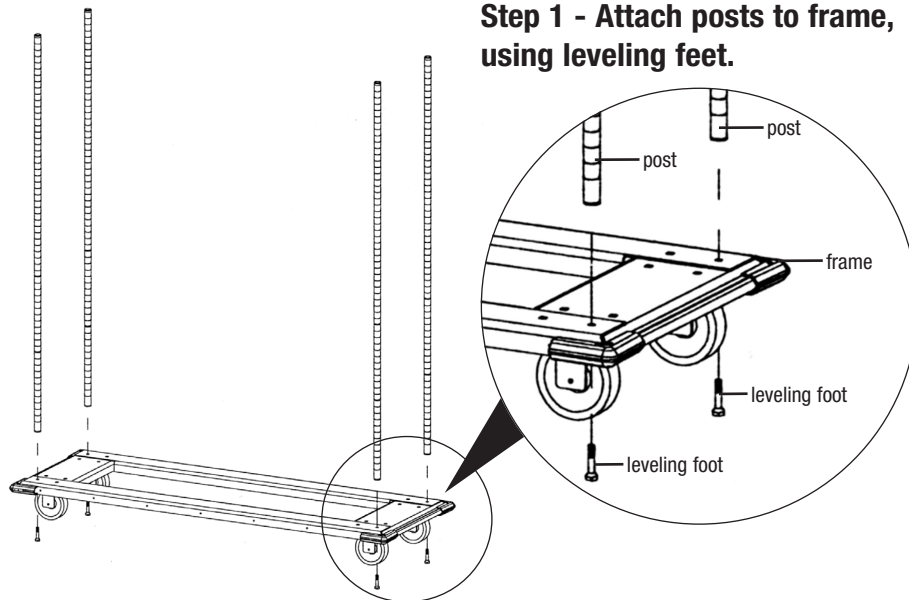
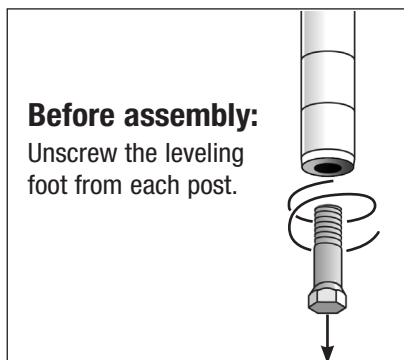

### Step 2 - Attach bottom shelf to posts.

- Snap the plastic split sleeves onto each post at the bottommost groove.  
*Note: The wider part of the split sleeve is the bottom.*
- Lower the bottom shelf onto split sleeves.

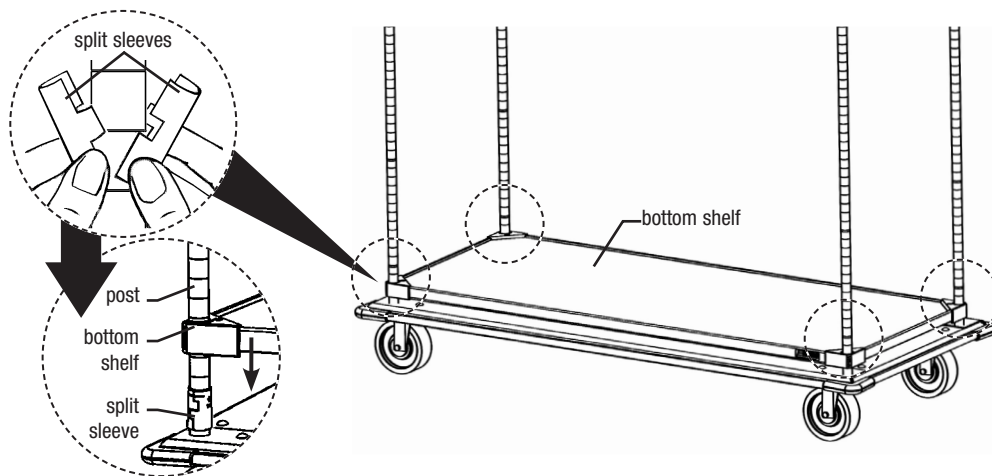

(continued on back page)

EG10123 Revised 05/24

# Heavy Duty Linen Carts

## ASSEMBLY INSTRUCTIONS

Working from bottom to top, repeat Step 2 to attach each wire shelf at desired height\*, until all shelves are attached.

**\* IMPORTANT NOTE:**  
Top shelf must be attached to top groove of post.

For each shelf, snap split sleeve onto each post at the same height (the wider part of the taper goes toward the bottom).

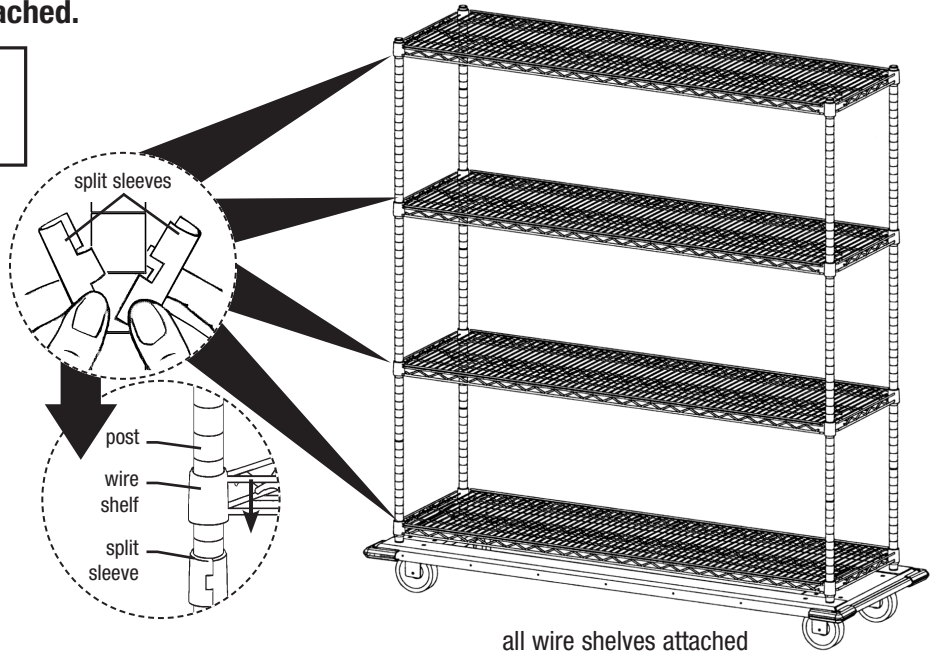

all wire shelves attached

### Step 3 - Attach side panels.

- Hook top and bottom of side panel, as shown.
- Affix with retaining screws, as shown.
- Repeat on remaining side panel.

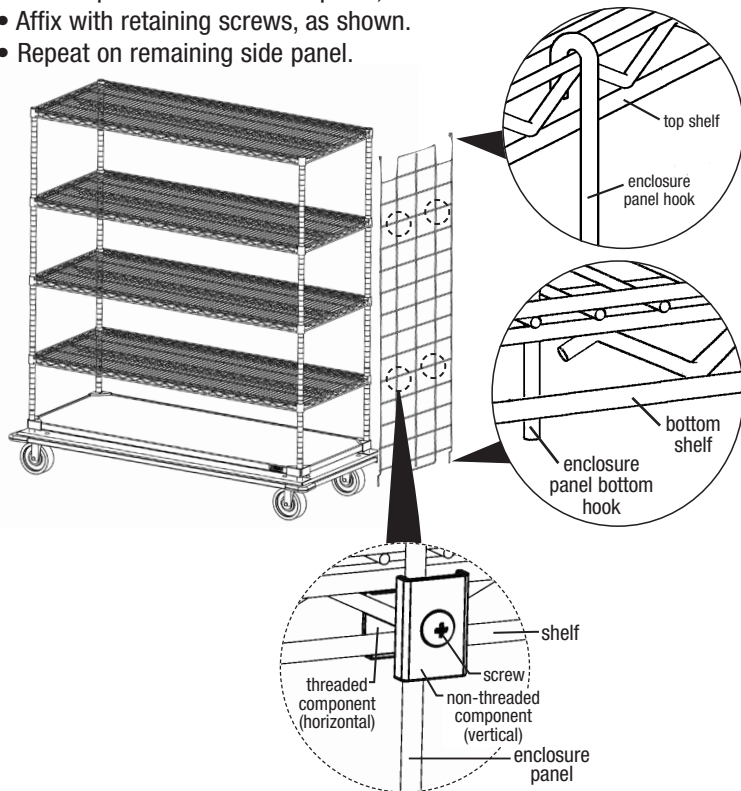

### Step 4 - Attach rear panels.

Repeat Step 3 to attach rear panels.

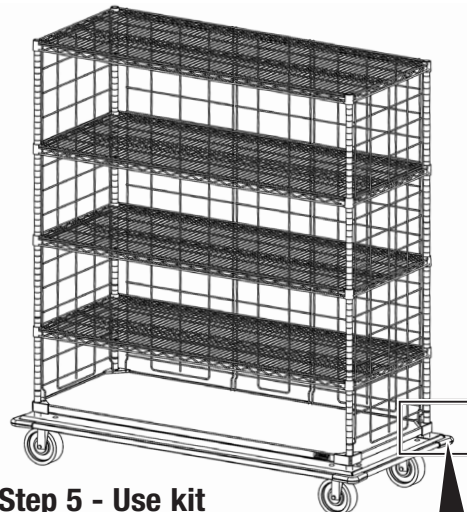

### Step 5 - Use kit #SENCBKT to secure side and rear panels to bottom solid shelf.

NOTE: Comes with two left and two right clips (for two enclosure panels). For bottom solid shelves only!

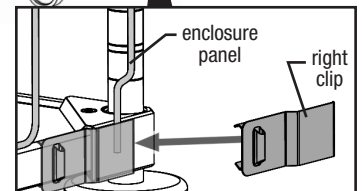

(End)