



Profit from the Eagle Advantage®

# Specification Sheet

## Short Form Specifications

Eagle Packaged Glove Dispenser, model \_\_\_\_\_, #4 brushed finish. Type 304 stainless steel construction. Features hinged lid, closed body, and mounting hardware covers. Single compartment is 12¼" wide, 24⅛" tall, and 7¾" deep. Compartment is sized for folded garments, such as scrubs, gowns, and aprons. May be customized for specific sizes.



#SSC-CGD-1



#SSC-CGD-2

Item No.:	_____
Project No.:	_____
S.I.S. No.:	_____

# Gowning Dispensers— Packaged Glove Dispensers

## MODELS:

- SSC-CGD-1
- SSC-CGD-2
- SSC-CGD-3

## Design and Constructions Features

- Type 304 stainless steel construction.
- #4 brushed finish.
- Features hinged lid, closed body, and mounting hardware covers.
- Single compartment is 12¼" wide, 24⅛" tall, and 7¾" deep (311 x 611 x 197mm).
- Compartment is sized for folded garments, such as scrubs, gowns, and aprons.
- May be customized for specific sizes.

## EAGLE GROUP

100 Industrial Boulevard, Clayton, DE 19938-8903 USA  
 Phone: 302-653-3000 • 800-441-8440 • Fax: 302-653-2065  
[www.eaglegrp.com](http://www.eaglegrp.com)  
[www.eaglemhc.com](http://www.eaglemhc.com)

For custom configuration or fabrication needs, contact our **SpecFAB® Division**.  
 Phone: 302-653-3000 • Fax: 302-653-2065 • e-mail: [quotes@eaglegrp.com](mailto:quotes@eaglegrp.com)



EG03.92 Rev. 10/24

Spec sheets available for viewing, printing or downloading from our online literature library at our websites

Eagle Foodservice Equipment, Eagle MHC, and SpecFAB® are divisions of Eagle Group. ©2024 by the Eagle Group



Item No.: \_\_\_\_\_  
 Project No.: \_\_\_\_\_  
 S.I.S. No.: \_\_\_\_\_

## Gowning Dispensers—Packaged Glove Dispensers

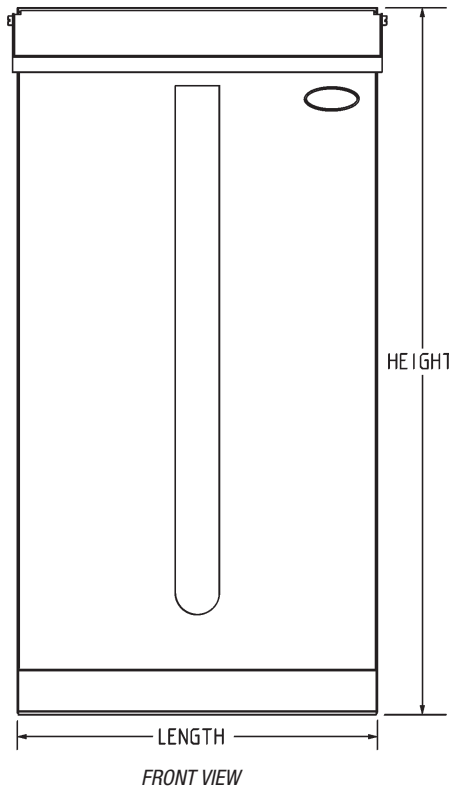
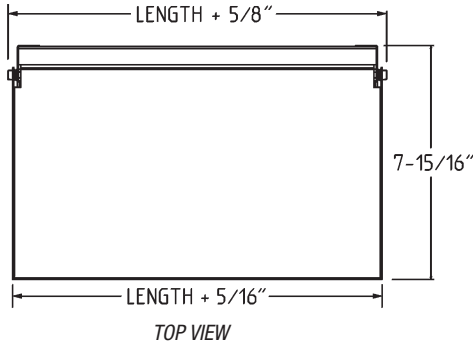

length		height		weight		quantity of bays	model #
in.	mm	in.	mm	lbs.	kg		
12¼"	311	24⅙"	611	17	7.7	1	SSC-CGD-1
24½"	622	24⅙"	611	27	12.3	2	SSC-CGD-2
36¾"	933	24⅙"	611	38	17.2	3	SSC-CGD-3

**EAGLE GROUP**  
 100 Industrial Boulevard, Clayton, DE 19938-8903 USA  
 Phone: 302-653-3000 or 800-441-8440 • Fax: 302-653-2065  
 www.eaglegrp.com • www.eaglehmc.com

Printed in U.S.A.  
 ©2024 by Eagle Group

Rev. 10/24

Spec sheets available for viewing, printing or downloading from our online literature library at our websites

Although every attempt has been made to ensure the accuracy of the information provided, we cannot be held responsible for typographical or printing errors. Information and specifications are subject to change without notice. Please confirm at time of order.