



Profit from the Eagle Advantage®

# Specification Sheet

## Short Form Specifications

Eagle Garment Dispenser, model \_\_\_\_\_.  
#4 brushed finish. Type 304 stainless steel construction. Features hinged lid, open front, high visibility level slots, and mounting hardware covers. Two models available, both are single-compartment. Sized for folded garments, such as scrubs, gowns, and aprons. May be customized for specific sizes.

Item No.:	_____
Project No.:	_____
S.I.S. No.:	_____

# Gowning Dispensers— Garment Dispensers

### MODELS:

- SSC-OAD-1014
- SSC-OAD-1216



#SSC-OAD-1014

### Design and Constructions Features

- Type 304 stainless steel construction.
- #4 brushed finish.
- Features hinged lid, open front, high visibility level slots, and mounting hardware covers.
- #SSC-OAD-1014 is 14¼" wide, 29¾" tall, and 10¼" deep (362 x 756 x 260mm).
- #SSC-OAD-1216 is 16¼" wide, 29¾" tall, and 12¼" deep (413 x 756 x 311mm).
- Compartment is sized for folded garments, such as scrubs, gowns, and aprons.
- Customized compartment sizes available.

### EAGLE GROUP

100 Industrial Boulevard, Clayton, DE 19938-8903 USA  
 Phone: 302-653-3000 • 800-441-8440 • Fax: 302-653-2065  
 www.eaglegrp.com  
 www.eaglemhc.com

For custom configuration or fabrication needs, contact our **SpecFAB® Division**.  
 Phone: 302-653-3000 • Fax: 302-653-2065 • e-mail: quotes@eaglegrp.com



EG03.91 Rev. 10/24

Spec sheets available for viewing, printing or downloading from our online literature library at our websites

Eagle Foodservice Equipment, Eagle MHC, and SpecFAB® are divisions of Eagle Group. ©2024 by the Eagle Group



Item No.: \_\_\_\_\_  
 Project No.: \_\_\_\_\_  
 S.I.S. No.: \_\_\_\_\_

## Gowning Dispensers—Garment Dispensers

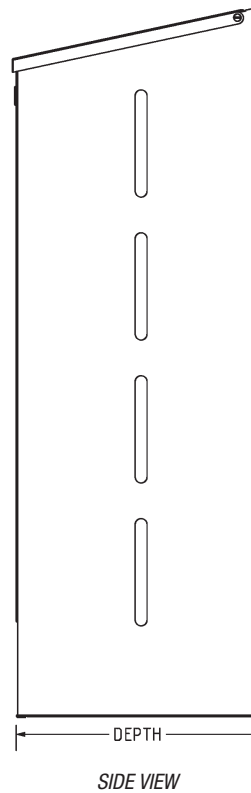
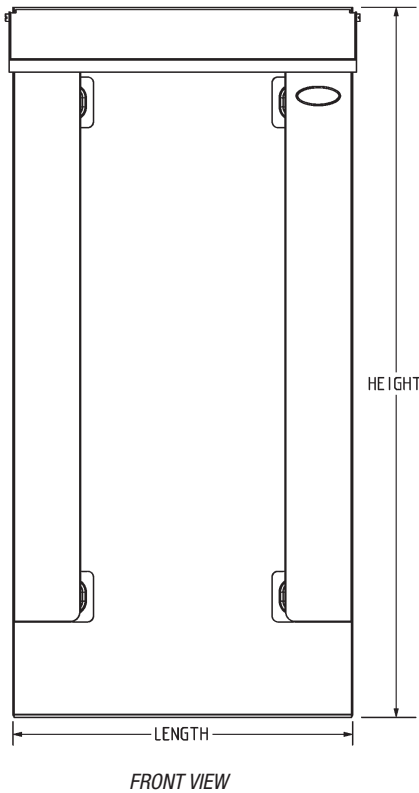
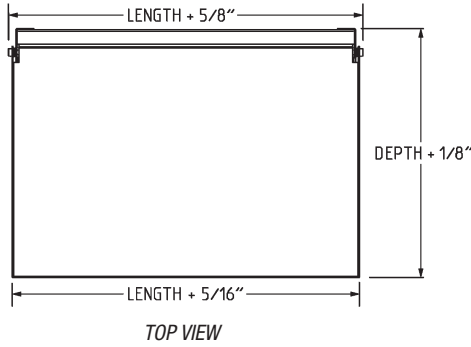

length		depth		height		weight		model #
in.	mm	in.	mm	in.	mm	lbs.	kg	
14¼"	361	10¼"	260	29¾"	756	24	10.9	SSC-OAD-1014
16¼"	413	12¼"	311	29¾"	756	27	12.3	SSC-OAD-1216

**EAGLE GROUP**  
 100 Industrial Boulevard, Clayton, DE 19938-8903 USA  
 Phone: 302-653-3000 or 800-441-8440 • Fax: 302-653-2065  
 www.eaglegrp.com • www.eaglehmc.com

Printed in U.S.A.  
 ©2024 by Eagle Group  
 Rev. 10/24

Spec sheets available for viewing, printing or downloading from our online literature library at our websites

Although every attempt has been made to ensure the accuracy of the information provided, we cannot be held responsible for typographical or printing errors. Information and specifications are subject to change without notice. Please confirm at time of order.