



Profit from the Eagle Advantage®

Specification Sheet

Short Form Specifications

Eagle Eye Protection Holder, model _____, #4 brushed finish. Type 304 stainless steel construction. Features sloped open compartments fabricated as a lift-off hinged compartment. Hinged access allows for cleaning of compartments. Lift-off access allows for deep cleaning. Compartments are sized for safety glasses and may be customized for goggles and other PPE. Compartments are 3⁵/₁₆" wide, 2⁵/₁₆" high, and 6¹/₂" deep. Customized compartment size and quantity available.

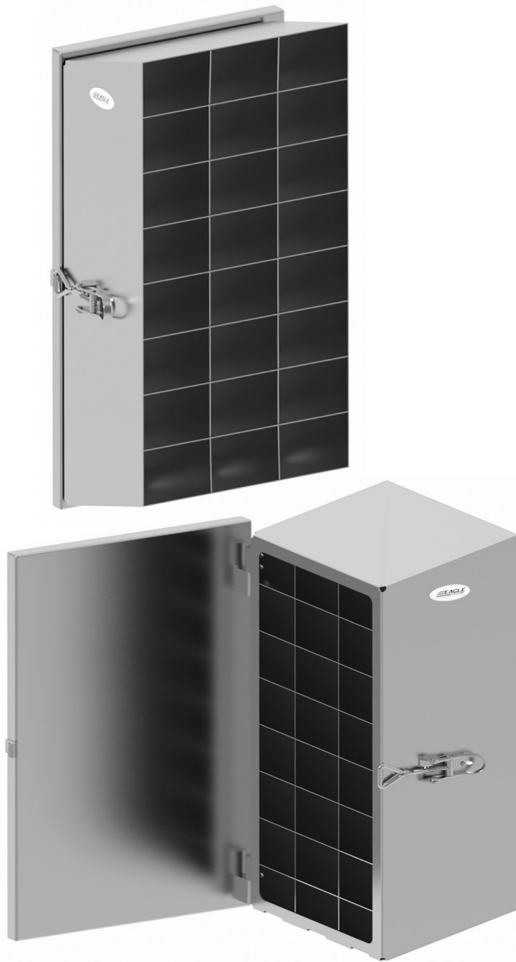

#SSC-EPH-24

EAGLE GROUP

100 Industrial Boulevard, Clayton, DE 19938-8903 USA
Phone: 302-653-3000 • 800-441-8440 • Fax: 302-653-2065
www.eaglegrp.com
www.eaglemh.com

For custom configuration or fabrication needs, contact our **SpecFAB®** Division.
Phone: 302-653-3000 • Fax: 302-653-2065 • e-mail: quotes@eaglegrp.com

Item No.: _____
Project No.: _____
S.I.S. No.: _____

Gowning Dispensers— Eye Protection Holders

MODELS:

- SSC-EPH-12**
- SSC-EPH-18**
- SSC-EPH-24**
- SSC-EPH-32**
- SSC-EPH-40**
- SSC-EPH-48**

Design and Constructions Features

- Type 304 stainless steel construction.
- Lift-off hinged compartment features sloped openings.
- Lift-off access allows for deep cleaning.
- Compartments are sized for safety glasses and may be customized for goggles and other PPE.
- Compartments are 3⁵/₁₆" wide, 2⁵/₁₆" high, and 6¹/₂" deep (84 x 58 x 165mm).
- Compartment size and quantity can be customized to specific needs.





Item No.: _____
 Project No.: _____
 S.I.S. No.: _____

Gowning Dispensers—Eye Protection Holders

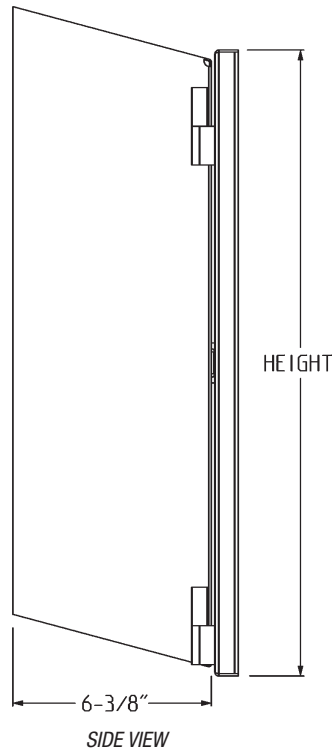
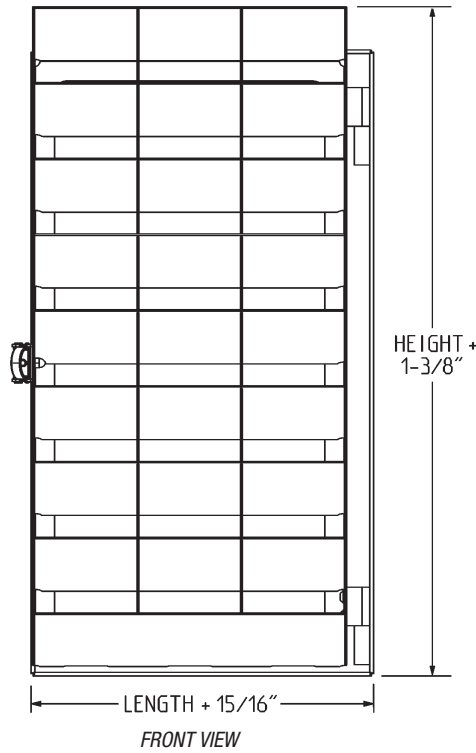
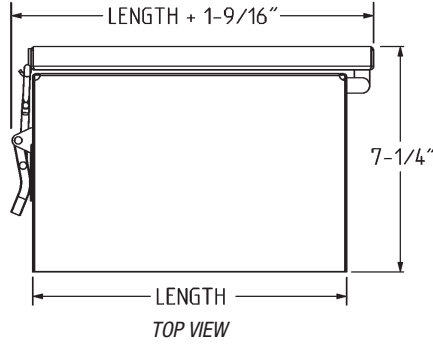

length		height		weight		quantity of compartments	model #
in.	mm	in.	mm	lbs.	kg		
10 ¹ / ₈ "	257	10 ⁷ / ₁₆ "	265	17	7.7	12	SSC-EPH-12
10 ¹ / ₈ "	257	15 ⁵ / ₁₆ "	389	22	10.0	18	SSC-EPH-18
10 ¹ / ₈ "	257	20 ¹ / ₄ "	514	27	12.3	24	SSC-EPH-24
13 ¹ / ₂ "	343	20 ¹ / ₄ "	514	35	15.9	32	SSC-EPH-32
16 ⁷ / ₈ "	429	20 ¹ / ₄ "	514	43	19.5	40	SSC-EPH-40
20 ⁹ / ₁₆ "	513	20 ¹ / ₄ "	514	50	22.7	48	SSC-EPH-48

EAGLE GROUP
 100 Industrial Boulevard, Clayton, DE 19938-8903 USA
 Phone: 302-653-3000 or 800-441-8440 • Fax: 302-653-2065
 www.eaglegrp.com • www.eaglehmc.com

Printed in U.S.A.
 ©2024 by Eagle Group

Rev. 10/24

Spec sheets available for viewing, printing or downloading from our online literature library at our websites

Although every attempt has been made to ensure the accuracy of the information provided, we cannot be held responsible for typographical or printing errors. Information and specifications are subject to change without notice. Please confirm at time of order.