



Profit from the Eagle Advantage®

Specification Sheet

Short Form Specifications

Eagle MHC Fixed Height Lab Bench, model #_____. All Stainless Steel type 304 Lab Bench with #4 brushed finish. Worksurface height is 36". Overall height 72". Frame and leg constructed with 2" square tubes. Legs provided with leveling mounts. 16 Gauge Type 304 Countertop, 1" thick, with square edge on all sides. Slotted rear uprights with (2) 16 gauge Lab style shelves with 1-1/4" rear upturn, square edge front & upturned bookends. Designed to meet the SEFA recommended practices.



unit with fixed height

Item No.:	_____
Project No.:	_____
S.I.S. No.:	_____

Fixed Height Lab Benches

MODELS:

- SSC-HTLB-3036-72-D
- SSC-HTLB-3048-72-D
- SSC-HTLB-3060-72-D
- SSC-HTLB-3072-72-D
- SSC-HTLB-3084-72-D
- SSC-HTLB-3096-72-D

Design and Construction Features

- 304 stainless steel construction with #4 brushed finish
- 2" (51mm) tubular frame legs
- 16 gauge square edge worksurface – 1" (25mm)-thick
- Legs provided with leveling mounts
- 16 gauge adjustable shelves

Options / Accessories

- Raceway provided with NEMA L5-20P, 1 NEMA 5-20R GCFI and additional 5-20R receptacles, dependent on length
- Suspended drawer assemblies
- Pedestal assemblies (sold separately)
- Lights
- Keyboard tray
- Monitor arms
- Bin rail
- Phenolic top
- Epoxy resin top
- Casters
- Type 316 stainless steel construction
- Custom sizes/configurations

EAGLE GROUP

100 Industrial Boulevard, Clayton, DE 19938-8903 USA
 Phone: 302-653-3000 • 800-441-8440 • Fax: 302-653-2065
www.eaglegrp.com
www.eaglemhc.com

For custom configuration or fabrication needs, contact our SpecFAB® Division.
 Phone: 302-653-3000 • Fax: 302-653-2065 • e-mail: quotes@eaglegrp.com



EG03.83 Rev. 02/25

Spec sheets available for viewing, printing or downloading from our online literature library at our websites



Item No.: _____
 Project No.: _____
 S.I.S. No.: _____

Fixed Height Lab Benches

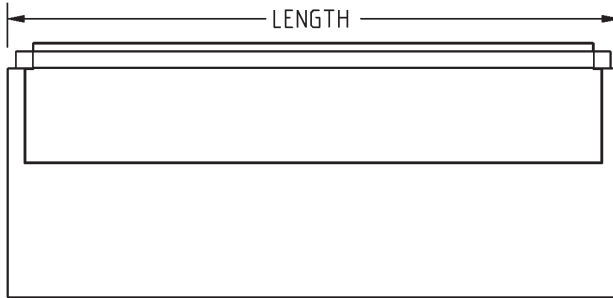

TOP VIEW

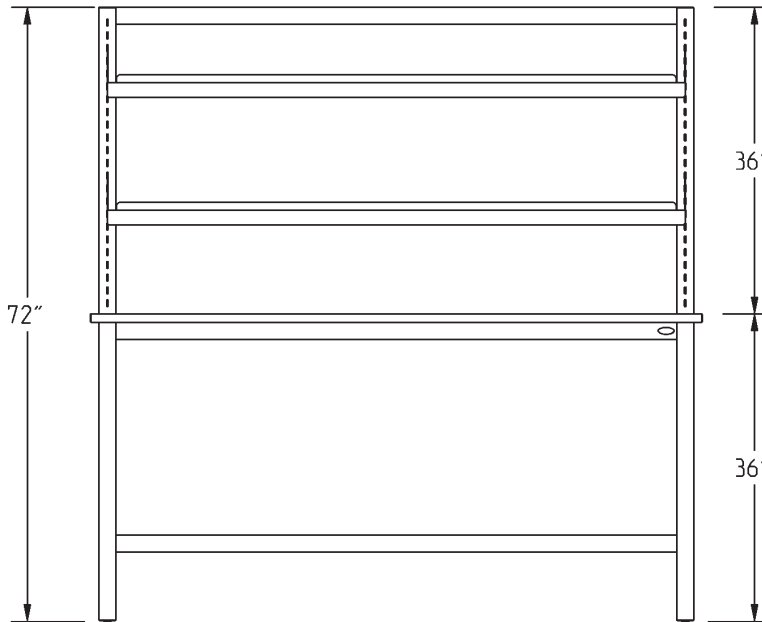

FRONT VIEW

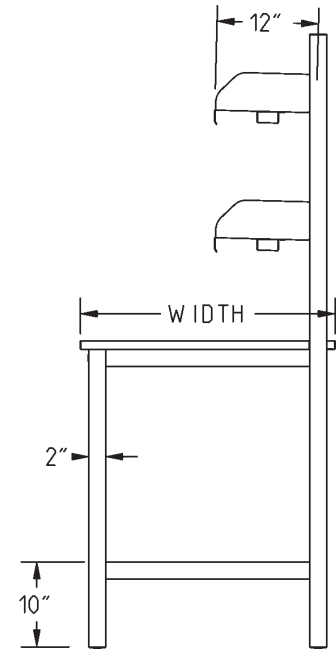

SIDE VIEW

width		length		model #
in.	mm	in.	mm	
30"	762	36"	914	SSC-HTLB-3036-72-D
30"	762	48"	1270	SSC-HTLB-3048-72-D
30"	762	60"	1524	SSC-HTLB-3060-72-D
30"	762	72"	1829	SSC-HTLB-3072-72-D
30"	762	84"	2134	SSC-HTLB-3084-72-D
30"	762	96"	2438	SSC-HTLB-3096-72-D

EAGLE GROUP
 100 Industrial Boulevard, Clayton, DE 19938-8903 USA
 Phone: 302-653-3000 or 800-441-8440 • Fax: 302-653-2065
 www.eaglegrp.com • www.eaglehmc.com

Printed in U.S.A.
 ©2025 by Eagle Group

Rev. 02/25

Spec sheets available for viewing, printing or downloading from our online literature library at our websites

Although every attempt has been made to ensure the accuracy of the information provided, we cannot be held responsible for typographical or printing errors. Information and specifications are subject to change without notice. Please confirm at time of order.